

AC Current transducer AKR-C420L

$I_{PN} = 2..200A$

Transducer for the electronic measurement AC waveforms current, with galvanic isolation between the primary (High power) and the secondary circuits (Electronic circuit). Jumper selectable ranges and True RMS 4-20mA current output.



Features

- VFD and SCR waveforms current measurement
- True RMS responding
- 4-20 mA Current output
- Loop powered transducers
- Panel mounting
- Accurate
- Jumper selectable ranges

Electrical data

Primary Nominal Current I_{PN} (A.t.RMS)	Analogue Output Signal ¹⁾ I_{OUT} (mA)	Type
2,5	4-20	AKR 5 C420L
10,20,50	4-20	AKR 50 C420L
100,150,200	4-20	AKR 200 C420L

V_c	Supply voltage (Loop powered)	24	V DC
R_L	Load resistance	see power supply diagram	
V_d	RMS Isolation voltage test, 50 Hz, 1mn	5	kV AC
f	Frequency bandwidth	20-100	Hz

Advantages

- Large aperture
- High isolation between primary and secondary circuits
- Easy to mount

Accuracy - Dynamic performance data

X	Accuracy @ I_{PN} , $T_A=25^\circ C$	± 1	%
t_r	Response time @ 90% of I_{PN}	< 600	mS

Applications

- VFD Controlled Loads:
VFD output indicates how the motor and attached load are operating.
- SCR Controlled Loads:
Accurate measurement of phase angle fired or burst fired (time proportioned) SCRs.
- Switching Power Supplies and Electronic Ballasts:
True RMS sensing is the most accurate way to measure power supply or ballast input power.

General data

T_A	Ambient operating temperature (0-95% RH)	-20..+50	$^\circ C$
T_S	Ambient storage temperature	-20..+85	$^\circ C$
m	Mass	90	g

Note: ¹⁾ For 4-20mA output model, no saturation output up to 23 mA

Selecting the transducer

VFD (Variable Frequency Drive) and SCR (Semi Conductor Rectifier) output waveforms are rough approximations of a sine wave. There are numerous spikes and dips in each cycle. AKR transducers use a mathematical algorithm called "True RMS," which integrates the actual waveform over time. True RMS is the only way to accurately measure distorted AC waveforms. *Select AKR transducers for nonlinear loads or in "noisy" power environments.*

Options on request

- DIN mounting

031219/4

Dimensions AKR-C420L (unit : mm, 1mm = 0.0394 inch)

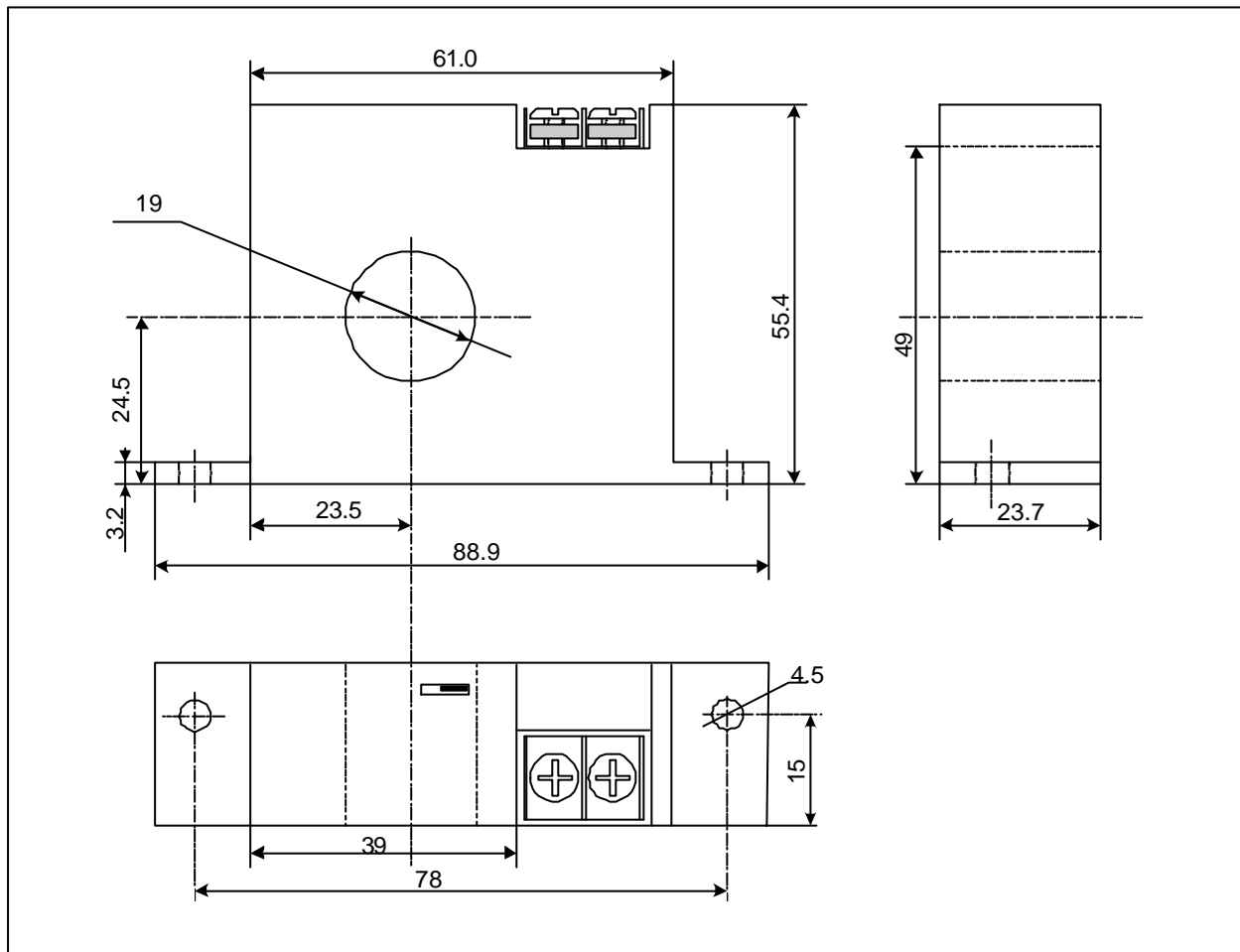

Mechanical characteristics

- General tolerance ± 1 mm
- Primary aperture 19 mm
- Panel mounting 2 holes $\varnothing 4.5$ mm
- Distance between holes 78 mm

Power Supply diagram

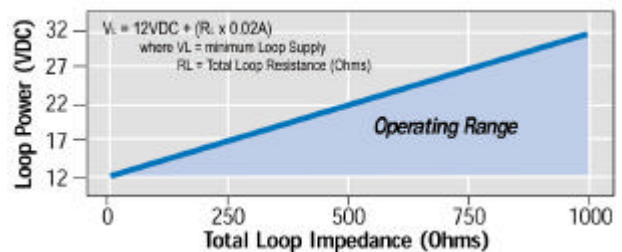

Connections

- 2 x UNC8 Cylindric Head

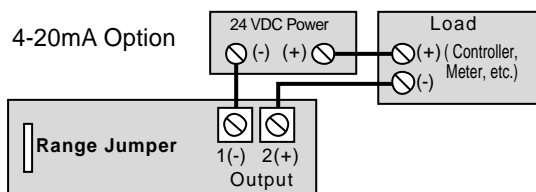

- Notes:
- Captive screw terminals.
 - 12-22 AWG solid or stranded.
 - Observe polarity.