

AC Current transducer AK-C-

$I_{PN} = 10..200A$

Transducer for the electronic measurement AC sinusoidal waveforms current, with galvanic isolation between the primary (High power) and the secondary circuits (Electronic circuit). Jumper selectable ranges and self powered transducers.

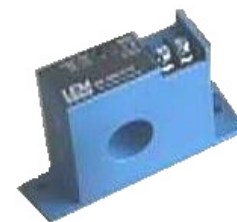

Electrical data

Primary Nominal Current	Analogue Output Signal ¹⁾	Type
I_{PN} (A.t.RMS)	V_{OUT} (V DC)	
10,20,50	5	AK 50 C5
10,20,50	10	AK 50 C10
100,150,200	5	AK 200 C5
100,150,200	10	AK 200 C10

V _c	Supply voltage	Self Powered	
R _L	Load resistance	1	MΩ
V _d	RMS Isolation voltage test, 50 Hz, 1 mn	5	kV AC
f	Frequency bandwidth	50-60	Hz

Features

- AC sinusoidal measurement
- Average responding
- Self powered transducers
- Panel mounting
- Voltage output
- Jumper selectable ranges

Advantages

- Large aperture
- High isolation between primary and secondary circuits
- Easy to mount

Accuracy - Dynamic performance data

X	Accuracy @ $I_{PN}, T_A = 25^\circ C$	± 1	%
t _r	Response time @ 90% of I_{PN}	< 100	mS

Applications

- Automation systems
Analog current reading for remote monitoring (e.g. motor).
- Data loggers
Self-powered transducer does not drain data logger batteries.
- Panel meters
Simple connection displays power consumption.

General data

T _A	Ambient operating temperature (0-95% RH)	-20..+50	°C
T _S	Ambient storage temperature	-20..+85	°C
m	Mass	120	g

Note: ¹⁾ For 0-5 V output model, no saturation output up to 8.2 V and for 0-10 V output model, no saturation output up to 15 V

Options on request

- DIN mounting

Dimensions AK-C- (unit : mm, 1mm = 0.0394 inch)

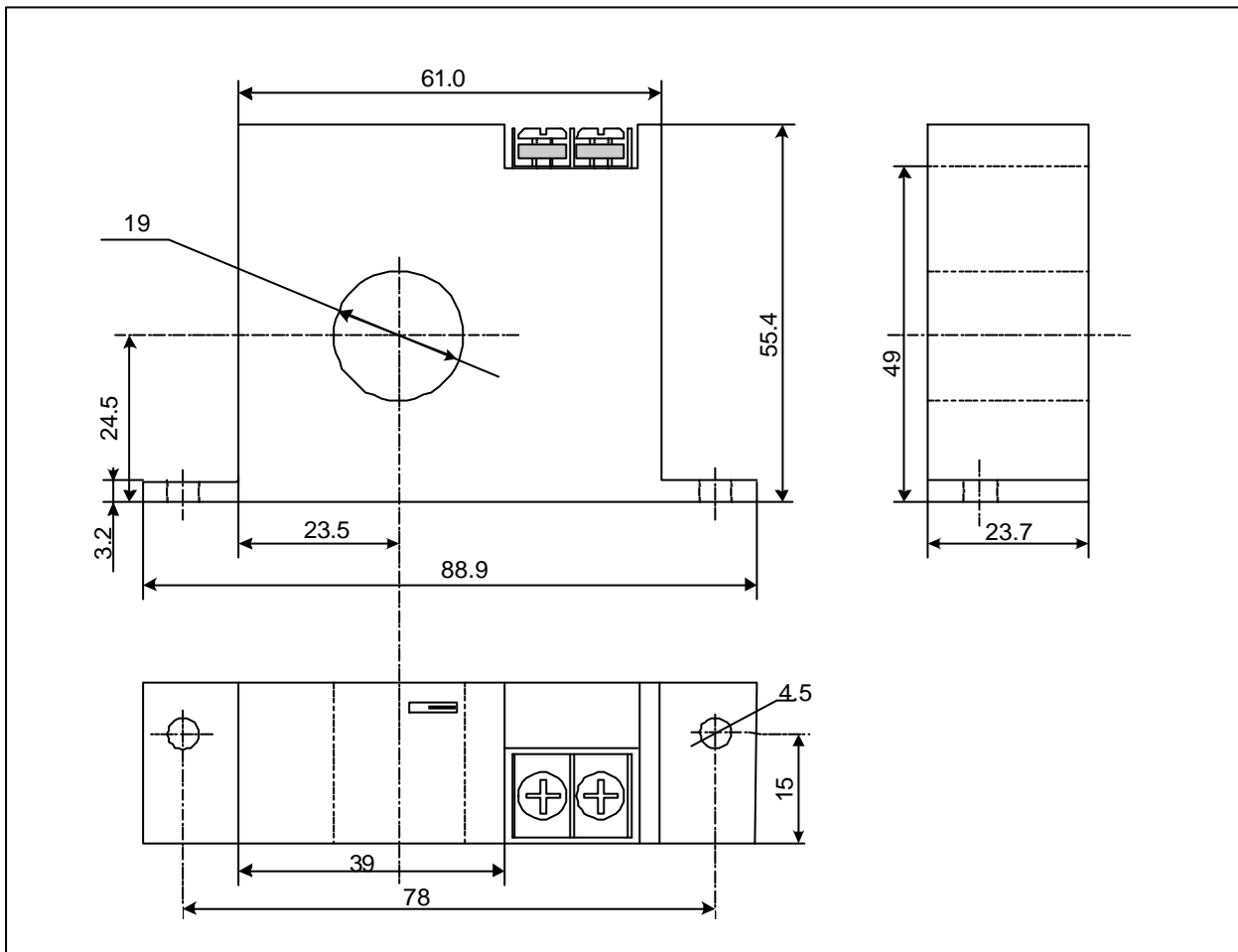

Mechanical characteristics

- General tolerance ± 1 mm
- Primary aperture 19 mm
- Panel mounting 2 holes $\varnothing 4.5$ mm
- Distance between holes 78 mm

Connections

- 2 x UNC8 Cylindric Head

