

# AC/DC Current transducer AHR-B420

$I_{PN} = 500..2000 \text{ A}$

The transducer for the electronic measurement DC & distorted AC waveforms current, with galvanic isolation between the primary (High power) and the secondary circuits (Electronic circuit). True RMS 4-20mA current output.



Preliminary

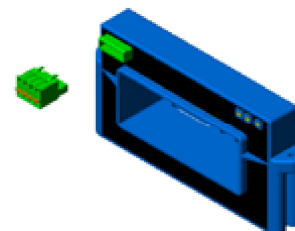

## Electrical data

Primary Nominal DC & AC Current	Primary AC Current Max. Peak Value (*)	Analogue Output Signal	Type
$I_{PN}$ (A.t.RMS)	$I_p$ (A)	$I_{OUT}$ (mADC)	
500	2000	4-20	<b>AHR 500 B420</b>
800	2500	4-20	<b>AHR 800 B420</b>
1000	2000	4-20	<b>AHR 1000 B420</b>
1500	2500	4-20	<b>AHR 1500 B420</b>
2000	3000	4-20	<b>AHR 2000 B420</b>

$R_L$	Load resistance	< 300	$\Omega$
$V_C$	Supply voltage	+20 .. 50	V DC
$I_C$	Current consumption	30 mA + $I_{OUT}$	
	Limitation of output current	< 25	mA
	Overloaded input current (Ampere Turns)	30000	At

## Accuracy-Dynamic performance data

$X$	Accuracy @ $I_{PN}$ , $T_A = 25^\circ\text{C}$ (excluding offset)	< $\pm 1$	% of $I_{PN}$
$e_L$	Linearity error (1% of $I_{PN} \dots \pm I_{PN}$ )	< $\pm 1.0$	% of $I_{PN}$
$I_{OE}$	Offset current, $T_A = 25^\circ\text{C}$	4mA	$\leq \pm 1.0$ % of $I_{PN}$
$I_{OT}$	Thermal drift of $I_{OE}$ (0..+60 °C)	$\pm 3.2$	$\mu\text{A/K}$
	(-40..+70 °C)	$\pm 6.4$	$\mu\text{A/K}$
$TCE_G$	Thermal drift of the gain including offset (% of reading)	$\pm 0.1$	%/K
$t_r$	Response time @ 90% of $I_p$	< 150	ms
$f$	Frequency bandwidth ( $\pm 1$ dB)	DC 20..6000	Hz

## General data

$T_A$	Ambient operating temperature	-40 .. +70	$^\circ\text{C}$
$T_S$	Ambient storage temperature	-40 .. +85	$^\circ\text{C}$
$m$	Mass	260	g
	Protection type	IP20	
	UL94 classification	V0	

**Notes :** - Installation and maintenance should be done with power supply disconnected.  
 - The operator must have accreditation to install this material.  
 - The users must take care of all protection guarantee against electrical shock.  
 (\*) The Max. Peak AC Current is the highest peak level of the primary signal that is taken into account for accurate True RMS calculation. Yet the device is designed for maximum continuous True RMS value equal to  $I_{PN}$ , whereas the output is limited by the above specified output limitation.

## Features

- VFD and SCR waveforms current measurement
- True RMS output
- 4-20mA current output
- Panel mounting
- Eliminates insertion loss
- Split core type (open-close model)

## Advantages

- High isolation between primary and secondary circuits
- Easy to mount

## Applications

- VFD Controlled Loads:  
VFD output indicates how the motor and attached load are operating.
- SCR Controlled Loads:  
Accurate measurement of phase angle fired or burst fired (time proportioned)  
SCRs. Current measurement gives faster response than temperature measurement.
- Switching Power Supplies and Electronic Ballasts:  
True RMS sensing is the most accurate way to measure power supply or ballast input power.

## Current Transducer AHR-B420

### Isolation characteristics

$V_b$	Rated Voltage with IEC 61010-1 acc. to the 61326 standards and following conditions : - Single insulation - Over voltage category CAT III - Pollution degree PD2 - None uniform field	1000	V
$V_d$	R.m.s. voltage for AC insulation test, 50Hz, 1min	5	kV
dCp	Creepage distance	11	mm
dCl	Clearance distance	11	mm
CTI	Comparative tracking index (Group I)	600	

#### Notes :

Output polarity with DC input

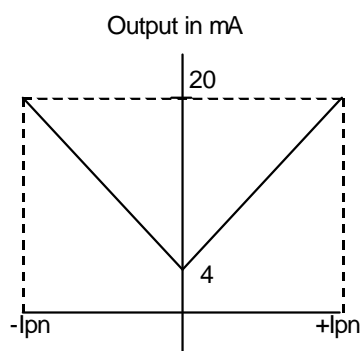

## Dimensions AHR-B420 (in mm. 1 mm = 0.0394 inch)

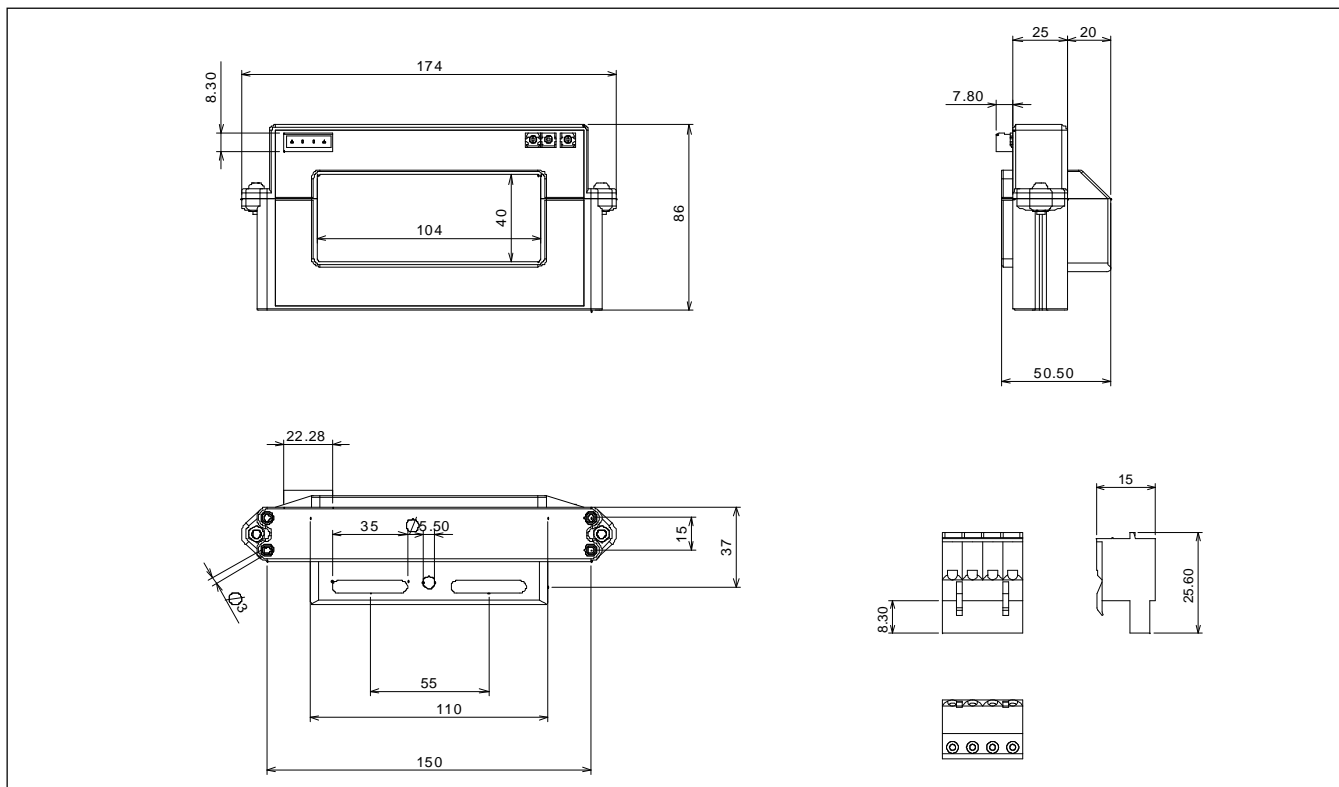

### Connections

- Wires up to 2 mm  $\varnothing$
- Female connector provided (screw terminals)

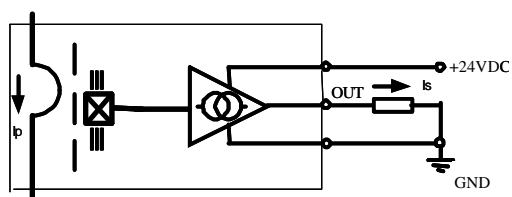
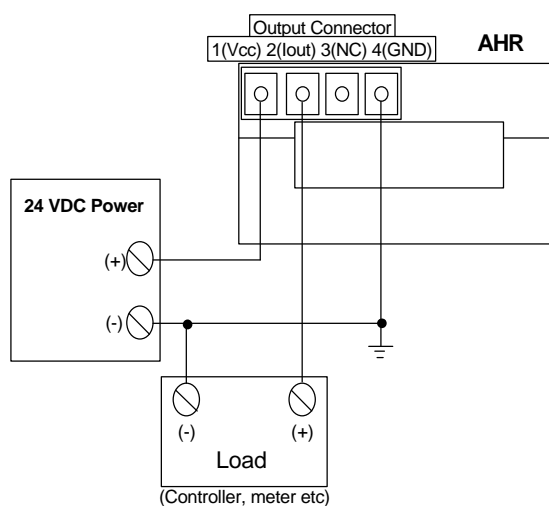

### Mechanical characteristics

- General tolerance  $\pm 1$  mm
- Primary aperture
- Panel mounting
- Distance between holes

For panel mounting, replace M4 screws by new one (not supplied) with appropriate length to panel's thickness.

### Safety



This transducer must be used in electric/electronic equipment with respect to applicable standards and safety requirements in accordance with the following manufacturer's operating instructions.



Caution, risk of electrical shock

When operating the transducer, certain parts of the module can carry hazardous voltage (eg. primary busbar, power supply). Ignoring this warning can lead to injury and/or cause serious damage.

This transducer is a built-in device, whose conducting parts must be inaccessible after installation.

A protective housing or additional shield could be used.

Main supply must be able to be disconnected.

051226/0